



# Bicam II

Professional modular camera for high-end digital photography



© Giovanni Bortolani

#### Technical information

dimensions	height 165mm, lenght 147mm, depth 50mm (compact)
weight	0,80 Kg.
vertical shift	15mm rise, 15mm fall
lenses attachment	Silvestri lens board, Silvestri bayonet
back attachment	Silvestri standard four points attachment
reference code	7000

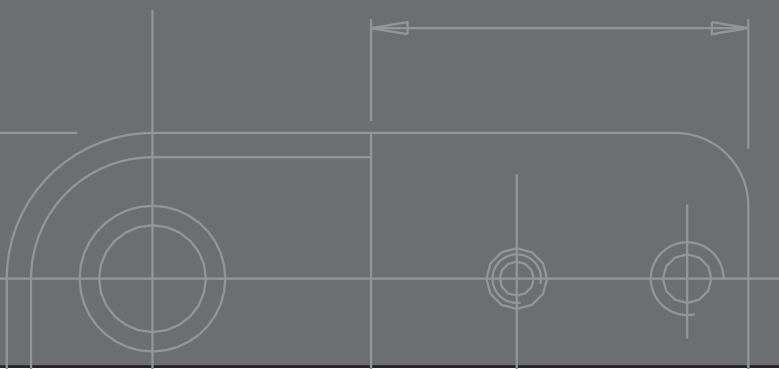



# Bicam II

Silvestri cameras are known for their combination of corrective movements with medium format portability. Now, in the film-plus-digital age, the Silvestri Bicam continues to satisfy your camera needs with ingenious solutions. It is compact, flexible and efficient. You start with an 0,8 kg weight (body only, including quick-mount device). You add the back for conventional film operation or you integrate a high-resolution digital back. For both conventional and digital operation, the user has access to Silvestri's broad range of front and rear accessories. This is an versatile system which develops and adapts to the needs of the photographer.

Bicam has a particular knack for wide-angle photography. This is where we encounter greatly reduced distances from lens to focal plane, threatening flexibility of movements. Also, precise focusing and parallel alignment of planes are major concerns. Bicam, with its rigid construction, can solve the problems.

Bicam is versatile. It can in one moment pair up with a 28mm Digitar, then be combined with a Flexi-Bellow for use in studio, with an 80mm or 100mm Digitar. For rapid shooting, Bicam can function with Silvestri's wide-angle viewfinder; when perfect framing is required, Bicam couples quickly to the Sliding Back Adapter, bringing a ground-glass screen into action.



# Front Accessories



## Wide-angle shift modular camera



## Flexi Bellow Maxi



The Flexi Bellows Maxi mounts lenses with the Silvestri bayonet without the requirement of a helical focusing ring. Moreover the lenses can also be used on other view cameras via an adapter board with Silvestri bayonet attachment. The extension capability of the rail together with the advantage of the micrometric focusing extends the versatility of the Bicom 2 in still-life, industrial, architectural photography and in all the other fields where high quality performance is paramount. The Flexi Bellows Maxi features side shift movements and micrometric tilt and swing movements.

- Tilt 15+15 Micrometric adjustment with locking system.
- Swing 15+15 Micrometric adjustment with locking system.
- Extension: 75mm with click and micrometric adjustment.
- Side Shift 15+15mm.
- Possibility to move back the camera standard in order to clear wide angle lenses.
- Cylindrical and pillow-like flabby combined bellow.
- Made in high grade anodized aluminium with movement on trapezoidal rails with Teflon sliding block.
- Code 7002

## Extension Bayonet Rings

These bayonet rings extend the bellow range of 15mm and 30mm respectively. They are used to get closer to the subject when the extension of the Flexicam or the Flexi Bellows are not sufficient.

C0102 Bayonet Ring extension 15mm  
C0104 Bayonet Ring extension 30mm



## Actuator for Hasselblad V lenses



The Silvestri Actuator adapts Hasselblad lenses from the V series with Silvestri cameras for digital use. It performs the cocking and triggering functions normally executed inside the Hasselblad body. The generous image circles of Hasselblad lenses make them attractive when used with digital backs. Due to the lens weight, we suggest 50-60-80-120 & 150mm. Full corrective movements (shift, tilt, swing) are now available for those lenses.

1150 Actuator for Hasselblad V lenses with Silvestri bayonet - Long ( use with 1119 & 3565)  
1152 Actuator for Hasselblad V lenses with Silvestri bayonet - Short ( for Flexi Bellow maxi)

## Digital Lenses in Bayonet

Schneider	Copal 0	Prontor Magnetic	Schneider Electronic	Rodenstock	Copal 0	Prontor Magnetic
Digitar 2,8/28L	D7202	2329K	2329KS	HR Digaron S 4,5/28mm	D7226	2234K
Apo Digitar 5,6/47XL	D7218	2248K	2248KS	HR Digaron S 4/35mm	D7228	2236K
Apo Digitar 4/60N	D7206	2261K	2261KS	HR Digaron W 4,0/40mm	D7248	2346K
Apo Digitar 5,6/72L	D7207	2273K	2276KS	HR Digaron S 4/60mm	D7234	2266K
Apo Digitar 4/80N	D7208	2281K	2281KS	HR Digaron S 4/100mm	D7239	2268K
Apo Digitar 4,5/90N	D7212	2291K	2291KS	Apo Sironar Digital 4,5/45mm	D7230	2245K
Apo Digitar 5,6/100N	D7214	2214K	2214KS	Apo Sironar Digital 4,5/55mm	D7232	2255K
Apo Digitar 5,6/120N	D7216	2212K	2212KS	Apo Sironar Digital 5,6/70mm	D7233	2276K
Apo Digitar 5,6/150N	D7225	2215K	2215KS	Apo Sironar Digital 5,6/90mm	D7238	2293K
Apo Digitar 5,6/180T	D7248	2284K	2284KS	Apo Sironar Digital 5,6/105mm	D7240	2205K
				Apo Sironar Digital 5,6/135mm	D7242	2217K
				Apo Sironar Digital 5,6/150mm	D7244	2218K

# Lenses & Combinations



code 2334K  
Schneider Digitar  
35mm XL in focusing  
mount on special  
board.



code D7215  
Schneider Digitar 24XL  
in Copal 0 and focusing  
mount on special board.



code 2223K  
Rodenstock Digaron  
23HR in Prontor shutter  
and focusing mount on  
special board.

## Digital Lenses in focusing mount & accessories

Rodenstock	Copal 0	Prontor Magnetic		Lens board	Extension ring
HR Digaron S 5,6/23mm	D7336	2223K		Special board included	no
HR Digaron S 4,5/28mm	D7326	2232K		Board R code 1119	no
HR Digaron S 4/35mm	D7328	2235K		Board R code 1119	no
HR Digaron W 4,0/40mm	D7340	2246K		Board R code 1119	no
HR Digaron S 4/60mm	D7334	2264K		Board R code 1119	n.1 code 3565
HR Digaron W 5,6/70mm	D7339	2211K		Board R code 1119	n.2 code 3575
HR Digaron W 5,6/90mm	D7329	2233K		Board "E" code 1121	n.1 code 3575
HR Digaron S 4/100mm	D7330	2244K		Board "E" code 1121	n.2 code 3575
Apo Sironar Digital 4,5/35mm	D7332	2254K		Special board included	no
Apo Sironar Digital 4,5/45mm	D7333	2274K		Board R code 1119	no
Apo Sironar Digital 4,5/55mm	D7338	2292K		Board R code 1119	3R
Schneider	Copal 0	Prontor Magnetic	Schneider Electronic	Lens board	Extension ring
Apo Digitar 5,6/24XL	D7215	2324K	-	Special board included	no
Apo Digitar 2,8/28L	D7200	2328K	2328KS	Board R Cod. 1119	n.1 code 3565
Apo Digitar 5,5/35XL	D7222	2334K	-	Special board included	no
Apo Digitar 5,6/47XL	D7110	2247K	2247KS	Board R Cod. 1119	no
Apo Digitar 4/60N	D7112	2260K	2260KS	Board R Cod. 1119	no
Apo Digitar 5,6/72L	D7113	2272K	2275KS	Board "R" Cod. 1119	n.1 code 3565
Apo Digitar 4/80N	D7114	2280K	2280KS	Board "R" Cod. 1119	n.2 code 3575
Apo Digitar 4,5/90N	D7116	2290K	2290KS	Board "F" Cod. 1123	n.1 code 3565
Apo Digitar 5,6/100N	D7118		2210KS	Board "E" Cod. 1121	n.1 code 3565

## Lens Boards



Code 1118	Lens Board with bayonet Type S (6,5mm)
Code 1118D	Lens Board with bayonet Type S 10mm Shift (6,5mm)
Code 1119	Lens Board with bayonet Type R (3,5mm)
Code 1120	Lens Board with bayonet Type B (13,65mm)
Code 1121	Lens Board with bayonet Type E (24,8mm)
Code 1122	Lens Board with bayonet Type C (24mm)
Code 1123	Lens Board with bayonet Type F (17,55mm)
Code 1124	Extension Board Type D shift 15+15mm (40,3mm)
Code 1125	Lens Board with bayonet Type G

## Shutters



Copal 0 & 1 : Mechanical shutter with manual loading, manual diaphragm setting, times from 1 to 1/500 + B and T poses.

Copal Press 0 (for film photography only): Mechanical shutter with preselection of the diaphragm and automatic loading, times from 1 to 1/125 + B pose.

Prontor/Silvestri n. 0 : Magnetic shutter with electronic control, it is activated by the Silvestri Remote Control Unit code 7020K. This type of shutter is needed with Multishot and Microstep digital backs.

Selection of times from the remote control unit, selection of diaphragms from the shutter.

Schneider 0 shutter: Magnetic shutter with electronic control, it is activated by the Silvestri Remote Control Unit code 7053K: selection of times and diaphragms. Needed for Microstep and Multishot digital backs.

## Remote Control Unit for Prontor and Schneider electronic shutters.



The Digital Remote Control Unit interfaces digital backs, controls the Prontor/Silvestri electronic shutters, the diaphragm opening with the new Schneider shutters. The Digital Control Unit allows to take 4 and 16 microstep shots with Imacon-Hasselblad Ixpress back. Works with Silvestri Electronic Sliding Adapters.

Controls the Prontor and Schneider shutters a) single shot b) multishot with selectable times with increasings of 1/3 diaphragm c) Control full open d) Control of field depth with selected diaphragm e) during the depth controlling it is possible to change the work diaphragm.

code 7020K for Prontor shutters.  
code 7053K for Prontor and Schneider shutters.

# Rear Accessories



Extension rings, sliding back and live-video adapters, viewers



## Extension Rings

The extension rings are used to adjust the different lengths of the lenses. The rings n.1 and n.2 are also available in the shiftable 15+15mm version, which are useful to increase the rise or to combine the rise with the side shift movement.



Shiftable rings 15+15mm



# Sliding adapters

This new Sliding adapter is the product of our long experience in the manufacturing of professional cameras for high resolution digital photography.

The stitching facility enables the photographer to almost double the file size of his image by shooting two images, side by side, and joining through software. This option gives the photographer many possibilities over the standard chip format and angle of view of lenses available

Completely re-designed with a new system of drop-in adapter plates and with further improved characteristics of the sliding movement and overall precision.

The new drop-in system, allows the quick substitution of adapter plates; adapter plates are available for Hasselblad V, H, Leaf AFI and Mamiya 645 AFD attachments. The digital back can be positioned either horizontally or vertically according to your needs.



Code	Description
D7023	Slide Adapter 5x7 with Silvestri Attachment (without Drop-in Plate)
D7023H	Drop-in Plate for Slide Adapter 5x7 Hasselblad 'H' type (for D7023)
D7023V	Drop-in Plate for Slide Adapter 5x7 Hasselblad 'V' type (for D7023)
D7023M	Drop-in Plate for Slide Adapter 5x7 Mamiya 645 AFD type (for D7023)
D7023A	Drop-in Plate for Slide Adapter 5x7 Leaf AFI type (for D7023)



## Viewers for Sliding Adapters



code 5010 Magnifying bellow for stitching sliding adapter.



code 5030 Reflex viewer 6x9 for stitching sliding adapter.

## Live-video Adapters for Digital Backs

'Live video' adapters (not sliding) available with the following interfaces:

Hasselblad 'V'	code DF7020
Hasselblad 'H'	code DF7019
Contax 645	code DF7013
Mamiya 645 AFD	code DF7015



DF7020 6x6 Live-Video adapter with Hasselblad V interface + D7016 Hasselblad Type screen in metal frame 6x6 + Lupe 4x



© Asa 64

## Viewfinders

### Shiftable Viewfinder



In many occasions this type of viewfinder makes your work easier and helps in making the composition process faster. A very precise roof-style level is visible in the viewfinder. A series of format frames are available for specific lenses. The viewfinder has an adjustment option to move the format frame to simulate the 15-0-15mm shift movement. code 1080B



### 120 degrees Viewfinder



A high quality and excellent correction viewfinder, with a large field angle, very useful with extremely wide angle lenses. A very precise roof-style level is visible in the viewfinder. Interchangeable format screens are available, with vertical-horizontal overturn. code 0900



## Backs and rollfilm holders for film photography, basic format 6x7-6x9



The format backs have standard Graflock type attachments and ground glass for roll film holders Horseman and Mamiya RB. The 6x12 roll film holders come with the ground glass and the magnifying lens in bellow included.

Rodenstock and Schneider lenses are available in Silvestri bayonet and focusing mount from 38mm to 150mm. For details see our web site: [www.silvestricamera.com](http://www.silvestricamera.com)

- code 4090 Revolving back 6x7/9 with ground glass
- code 4092 6x7/9 Back with Ground Glass for Apo Grandagon 4,5/45
- code 4047 6x12 Back for 47XL, ground glass and magnifying glass in bellow included
- code 4020 6x12 Revolving Back for 58 & 65mm with Ground Glass & Magnifying Bellow
- code 4030 6x12 Revolving Back for 75mm with Ground Glass & Magnifying Bellow
- code 4040 4x5 Back with Fresnel Lens for 75mm
- code 4045 4x5 Back with Fresnel Lens for 65mm
- code 4046 4x5 Back with Fresnel Lens for 47XL
- code 6020 / 6040 Horseman roll film holder 6x7/6x9
- code 6070 Horseman roll film holder 6x12 (modified)



## Viewing Devices



code 5030 Adjustable Reflex viewer 6x9 for 6x7/9cm backs



code 5010 Magnifying Bellow for 6x9



code 5020 Magnifying glass in leather Bellow for 6x12



code 4050 Folding Hood for 4x5 inches Back

## Filter Holder



3300 Wide Angle Filter Holder 100x100mm

## Compendium



3205 Bellow Filter Holder Combination 75mm  
3305 Bellow Filter Holder Combination 100mm



3200 Wide Angle Filter Holder 75mm  
3300 Wide Angle Filter Holder 100mm

## Adapter Rings



- 3306 Adapter Ring 40,5mm
- 3307 Adapter Ring 49mm
- 3308 Adapter Ring 52mm
- 3309 Adapter Ring 58mm
- 3310 Adapter Ring 67mm
- 3313 Adapter Ring 72mm
- 3315 Adapter Ring 77mm
- 3317 Adapter Ring 82mm
- 3318 Adapter Ring 86mm
- 3319 Adapter Ring 95mm



© Studio Braida



**silvestri**

Silvestri srl  
via della Gora 13/5  
50025 Montespertoli (FI) - Italia

phone: +39.0571675049  
fax: +39.0571675919  
e-mail: [info@silvestricamera.com](mailto:info@silvestricamera.com)  
[www.silvestricamera.com](http://www.silvestricamera.com)